



**AGENDA**

**SPECIAL COUNCIL MEETING**

**TUESDAY 8 OCTOBER 2024**

Notice is given that the next Special Council Meeting of Tiwi Islands Regional Council will be held on:

- Tuesday 8 October 2024 in Wurrumiyanga Boardroom and Teams
- Commencing at 10:00 am

Your attendance at the meeting will be appreciated.

**Gina McPharlin**  
**Chief Executive Officer**

## TABLE OF CONTENTS

<b>1 WELCOME &amp; APOLOGIES</b> .....	<b>3</b>
1.1 Welcome and Opening of Meeting .....	3
1.2 Present .....	3
1.3 Apologies .....	3
1.4 Leave of Absence .....	3
1.5 Declaration of Interest of Members or Staff .....	3
<b>2 REPORTS FOR DECISION</b> .....	<b>4</b>
2.1 Purchase of New Garbage Truck .....	4
<b>3 NEXT MEETING</b> .....	<b>25</b>
<b>4 CLOSURE</b> .....	<b>25</b>

## 1 WELCOME & APOLOGIES

### 1.1 Welcome and Opening of Meeting

### 1.2 Present

### 1.3 Apologies

### 1.4 Leave of Absence

### 1.5 Declaration of Interest of Members or Staff

Section 73 of the Northern Territory *Local Government Act* states:

#### Section 73 Conflict of interest

- (1) A member has a **conflict of interest** in a question arising for decision by the council, local board or council committee if the member or an associate of the member has a personal or financial interest in how the question is decided.
- (2) This section does not apply if the interest is:
  - (a) an interest in a question about the level of allowances or expenses to be set for members; or
  - (b) an interest that the member or associate shares in common with the general public or a substantial section of the public; or
  - (c) an interest as an elector or ratepayer that the member or associate shares in common with other electors or ratepayers; or
  - (d) an interest that the member or an associate has in a non-profit body or association; or
  - (e) an interest of the member or an associate:
    - (i) in appointment or nomination for appointment to a body with predominantly charitable objects; or
    - (ii) in payment or reimbursement of membership fees, or expenses related to membership, in such a body; or
  - (f) an interest so remote or insignificant that it could not reasonably be regarded as likely to influence a decision.

#### Section 74 Disclosure of interest

- (1) As soon as practicable after a member becomes aware of a conflict of interest in a question that has arisen or is about to arise before the council, local board or council committee, the member must disclose the personal or financial interest that gives rise to the conflict (the **relevant interest**):
  - (a) at a meeting of the council, local board or council committee; and
  - (b) to the CEO.

(2) The CEO must record the disclosure in a register of interests kept for the purpose.

Section 12 of the Northern Territory Local Government (Administration) Regulations states:

**Section 12 Contents of register of interests**

The register of interests to be kept under section 74(2) of the Act must contain:

- (a) the name of the member making the disclosure; and
- (b) the nature of the interest that gives rise to the conflict of interest; and
- (c) the nature of the question on which the conflict of interest arises.

Does any Councillor or Senior Officer have any conflicts of interest to declare at this point of proceedings?

## 2 REPORTS FOR DECISION

---

**ITEM NUMBER:** 2.1  
**TITLE:** Purchase of New Garbage Truck  
**AUTHOR:** Nyaradzo Musasira, Governance & Compliance Coordinator

### **PURPOSE**

This report is provided to Council to request Councils approval to purchase a new garbage truck for \$450 000 for the Community of Wurrumiyanga.

### **BACKGROUND**

Wurumiyanga's garbage truck has been out of service for several weeks. The truck has had ongoing electrical problems caused by wear and tear due to the age of the truck and climatic conditions

Council purchased the Wurrumiyanga garbage truck as new in 2015 and has relied on this truck for waste management for the past nine (9) years. The general practise by other councils is to renew garbage trucks every two (2) to three (3) years.

The council has an obligation to the upkeep of the environmental health and safety of the Wurrumiyanga land and its people. Further, the practice of the Town Services team loading community bins by hand poses a significant work health and safety issue.

At Council's 24 September Ordinary Council Meeting, Council resolved to ask the Wurrumiyanga Local Authority (WLA) to consider the purchase of a new garbage truck using Local Authority Project Funds (LAPF). A Special WLA meeting was held on Tuesday 7 October 2024 and at this meeting it was agreed that a new garbage truck would be purchased for the Wurrumiyanga community.

### **ISSUES/OPTIONS/CONSEQUENCES**

The Wurrumiyanga garbage truck was purchased in 2015 for approximately \$230,000. Since then, equipment prices have risen considerably with quotes indicating the estimated cost of a new garbage truck (including freight) to be \$450,000. (Noting the quoted truck has a greater volume which will reduce travel to the waste site and accommodate the proposed Wurrumiyanga town development.)

Officers have considered refurbishing the truck. The advantage of refurbishment is it will be less costly. However, it means that there will be no garbage truck for an extended period, and this is considered unacceptable operationally and by the community.

With the high cost of the truck and significant investment of funds the purchase represents, WLA members asked Officers to ensure that a truck would be maintained adequately, and the truck would remain in the Wurrumiyanga community. A plan is to be put in place for the maintenance of the new truck and it was agreed that only trained personnel will be operating the new machine, and employees will be trained in how to operate the truck in due course. The truck will be parked at the Depot every afternoon and there will be security cameras for security purposes.

The purchase price of the truck is approximately \$450,000. Council purchases over \$250,000 fall outside the Chief Executive Officers financial delegation. Under the Local Government Act 2019 (Section 40 Delegation), the CEO has the authority to be delegated the power to enter into a contract below the threshold value determined by Council. The

Council's Financial Delegations Policy limits this value to \$250,000. As this contract exceeds the CEO's delegation threshold, the Council is required to endorse it.

### **RECOMMENDATION**

**That Council accept the purchase of the new garbage truck for a provisional amount of \$450 000 using the Local Authority Project Fund as agreed to by the Wurrimiyanga Local Authority.**

### **ATTACHMENTS**

1. Special Wurrimiyanga Local Authority Draft Minutes 7 October 2024 [2.1.1 - 3 pages]
2. Bandit - Isuzu FVY 240-300 6 x 4 Side Load Garbage Truck (1) [2.1.2 - 16 pages]



**MINUTES OF THE WURRUMIYANGA LOCAL AUTHORITY MEETING HELD IN THE  
WURRUMIYANGA BOARDROOM ON MONDAY 7 OCTOBER 2024 AT 10:30 AM**

---

**TABLE OF CONTENTS**

<b>1 WELCOME &amp; APOLOGIES</b> .....	<b>2</b>
1.1 Welcome and Opening of Meeting .....	2
1.2 Present .....	2
1.3 Apologies .....	2
1.4 Leave of Absence .....	2
1.5 Declaration of Interest of Members or Staff .....	2
<b>2 GENERAL BUSINESS</b> .....	<b>2</b>
<b>3 REPORTS FOR DECISION</b> .....	<b>3</b>
3.1 Purchase of Garbage Truck for Wurrumiyanga .....	3
<b>4 NEXT MEETING</b> .....	<b>3</b>
<b>5 CLOSURE</b> .....	<b>3</b>



**1 WELCOME & APOLOGIES**

**1.1 Welcome and Opening of Meeting**

The meeting opened at 10.30am.

The chairperson welcomed members and staff.

**1.2 Present**

<b>Members</b>	
Richard Tungutulum	Chairperson
Wayne Pilakui	Member
Ronald Tipungwuti	Member
Bradley Tipiloura	Member
Bonaventure Timaepatua	Member
Annunciata Papangamirri	Member
Savio Timaepatua	Member
Marie Francis Tipiloura	Member
Miriam Tipungwuti	Member
Leslie Tungatalum	Deputy Mayor
Stanley Tipiloura	Councilor
<b>STAFF</b>	
Gina McPharlin	Chief Executive Officer
Jayesh Vasandani	Acting Chief Financial Officer
John Ware	Manager Operations - Bathurst Islands
Paul OConnor	Manager Housing & Assets
Nyaradzo Musasira	Governance & Compliance Coordintor
Kesara Scrymgour	Governance Officer
<b>GUESTS</b>	
Nil	

**Minute Taker: Kesara Scrymgour**

**1.3 Apologies**

Mayor Lynette De Santis

**1.4 Leave of Absence**

**1.5 Declaration of Interest of Members or Staff**

Nil

**2 GENERAL BUSINESS**

Nil.



### **3 REPORTS FOR DECISION**

#### **3.1 Purchase of Garbage Truck for Wurrumiyanga**

##### **SWLA/1 RESOLUTION**

*Moved:* Bonaventure Timaepatua

*Seconded:* Marie Francis Tipiloura

**That the Wurrumiyanga Local Authority agreed to the purchase of a new garbage truck for a provisional amount of \$450 000 from the WLA funds.**

**CARRIED**

### **4 NEXT MEETING**

To be advised.

### **5 CLOSURE**

The meeting closed at 11.42am



---

**SEPTEMBER 30, 2024**

Quote is valid for 30 days

**PREPARED BY:**

Shane Sinclair

STG Global

ssinclair@stgglobal.net

---



**QUEENSLAND**

49 Motorway Circuit, Ormeau, QLD 4208

**NEW SOUTH WALES**

32/10 John Hines Avenue, Michinbury, NSW 2770

**VICTORIA**

29-31 Evolution Drive, Dandenong South, VIC 3175

**WESTERN AUSTRALIA**

25 Competition Way, Wangara WA

**PROPOSAL FOR  
SIDELOADER  
WASTE TRUCK**

NON-BINDING INDICATIVE OFFER

 [STGGLOBAL.NET](http://STGGLOBAL.NET)



# YOUR PROPOSAL

**JOHN WARE**

**TIWI ISLANDS SHIRE COUNCIL**

Dear John,

Firstly, thank you for the opportunity to present to you the STG Global product. I am pleased to submit to you, a proposal for a truck that suits your business requirements.

STG Global is committed to building the best quality specialised vehicles to cater for a broad range of industries. The right truck can make a huge difference to the efficiency of your operations, especially when it comes to prompt maintenance and reducing downtime. Our product range is renowned for its reliability, durability and versatility.

STG Global is committed to quality service and strongly believes that carefully planned service truck designs and attention to detail is the key to success within the industry.

The STG Global team and I, look forward to a successful business partnership with you.

This quotation is valid for 30 days from the date of this proposal. Price quoted does not include any on road costs including registration or stamp duty, however it can be arranged.

I trust our proposal meets with your approval and I will contact you shortly to ensure that we have met your needs. If I can be of further assistance or should you require more information, please do not hesitate to contact me on 0457259256 or via email at [ssinclair@stgglobal.net](mailto:ssinclair@stgglobal.net)

Regards,

Shane Sinclair  
STG Global



# YOUR SPECIFICATIONS



## BODY

- Modern, aerodynamic body design
- Dual-cylinder compactor
- Watertight tailgate seal
- Individually controlled sliding front lifting forks
- Integrated storage
- Easy access to hydraulic units and electrical controls

## SAFETY

- Equipped with emergency stops
- Full OH&S compliance
- In-cab operator warning system
- CANBus control system with 12" touch screen iPad
- Safety interlocks on body access points
- Dual safety props for tailgate
- Active rear door locking system



## ELECTRIC AND HYDRAULIC CONTROLS

- Hose burst and counterbalance valves
- Compact on the move' capability
- Auto compact feature
- Proportional control valves
- STG Global's integrated iPad control system with full diagnostics
- 360° moveable joystick with full operations
- Enclosed hydraulics with easy service access

## LIGHTING

- Hella 'Shapeline' rear light modules with animated behaviour
- Single rear-mounted Hella low profile beacon
- Dual front-mounted Hella low profile beacons
- Reverse light and alarm

## MATERIAL SPECIFICATIONS

- Body side sheets –  
4 mm wear-resistant Hardox steel
- Body floor sheet –  
5 mm wear-resistant Hardox [HiAce](#) steel
- Body roof sheet –  
4 mm wear-resistant Hardox steel
- Compactor face sheet –  
5 mm wear-resistant Hardox steel
- Hopper wall sheet –  
3 mm wear-resistant Hardox steel
- Hopper floor sheet -  
4 mm wear-resistant Hardox steel
- Tailgate sheet – 3mm wear-resistant Hardox steel
- Fork blades – 20 mm wear resistant Hardox steel

## STANDARD ACCESSORIES

- Technical manual
- Anti-slip side access ladder with safety interlocks
- Premium single 2 pac white colour
- On demand training upon delivery
- Refresher training programs



# YOUR OFFER

DESCRIPTION	PRICE
NEW FVY 240-300 6X4 AUTO DUAL CONTROL CAB CHASSIS	\$195,807
<input checked="" type="checkbox"/> 20M3 STG BANDIT SIDELOADER BODY	\$198,640
<input type="checkbox"/> 22M3 STG BANDIT SIDELOADER BODY	\$199,242
<input type="checkbox"/> 24M3 STG BANDIT SIDELOADER BODY	\$199,825

## OPTIONS

Select from a range of Optional Extras to suit your budget & requirements:

### ANCILLARY OPTIONS

<input type="checkbox"/> Broom and Scraper Holders	\$570
<input type="checkbox"/> Autolube System - for truck chassis and body	\$17,500
<input type="checkbox"/> Fire Extinguisher - 9kg Single	\$650
<input type="checkbox"/> Fire Extinguisher - 9kg Twin	\$1,250
<input type="checkbox"/> Fire Extinguisher - 2.5kg in cab	\$314
<input type="checkbox"/> Fire Extinguisher - 1.1kg in cab	\$305
<input type="checkbox"/> Hand Wash Facility With Soap Dispenser Plastic - 23L w/ no drinking decal	\$475
<input type="checkbox"/> Manual Greasing System - all greasing points to one central point - waste compactor body	\$2,750
<input type="checkbox"/> Manual Greasing System - all greasing points to one central point - truck chassis	\$3,790
<input type="checkbox"/> Engine Fire Suppressant System - P.O.A	\$0



DESCRIPTION	PRICE
<input type="checkbox"/> Body Fire Suppressant System - P.O.A	\$0
<input type="checkbox"/> Spare Wheel Carrier - P.O.A	\$0
<input type="checkbox"/> Wheel Nut Indicators	\$150
<input type="checkbox"/> Breakdown Triangles	\$50
<input type="checkbox"/> Wheel Chocks	\$380
<input type="checkbox"/> Air Blower Behind Drivers Seat	\$150
<input type="checkbox"/> Canvas Seat Covers	\$250
<input type="checkbox"/> Canvas Seat Covers	\$595
<input type="checkbox"/> Rear Door Safety Props Painted Yellow	\$500
<input type="checkbox"/> First Aid Kit	\$70
<input type="checkbox"/> All Handles and Ladders Painted Yellow	\$1,350
<input type="checkbox"/> Supply & Fit Genuine Bullbar - P.O.A	\$0
<input type="checkbox"/> Window Tinting - Sides & Rear	\$300
<input type="checkbox"/> Weather Shield to Driver and Passenger Doors - P.O.A	\$0



DESCRIPTION	PRICE
<input type="checkbox"/> Battery Isolation switch w/lockout feature	\$650
<input type="checkbox"/> Safety Cutout Switch to muckout door	\$450
<input type="checkbox"/> Anderson Plug Jump Start	\$750
<input type="checkbox"/> Smart self adjusting reversing alarm "white sound"	\$355
<input type="checkbox"/> UHF TX4500 w/remote & antenna kit	\$1,250
<input type="checkbox"/> Side body floodlights w/override function & timer	\$795
<input type="checkbox"/> Diverseco TW2 6x4 with air rear and spring front suspension	\$7,800
<input type="checkbox"/> Camera System - Hopper/Rear	\$1,393
<input type="checkbox"/> Camera System - Hopper/Lifter/Rear Low/Rear High/LH Side/RH Side	\$6,800
<input type="checkbox"/> Reverse Alarm - Squawker	\$397
<input type="checkbox"/> Reverse Sensor - Brigade with in cabin visual and audible warning	\$3,617
<input type="checkbox"/> AEB (Automatic Breaking System) - P.O.A	\$0
<input type="checkbox"/> Front Pedestrian Detection System (motion detection system with alarm - Brigade fs-4000W	\$6,304
<input type="checkbox"/> Lifter Zone Pedestrian Sensor	\$12,000
<input type="checkbox"/> Auto-collect	\$12,000
<input type="checkbox"/> Remote Bin-lifter	\$3,000
<input type="checkbox"/> Door Open / Park Brake Not applied audible alarm with warning light	\$500
<b>DRIVER TRAINING</b>	
<input type="checkbox"/> 1 Day Training	\$0



DESCRIPTION	PRICE
<input type="checkbox"/> Door Open / Park Brake Not applied audible alarm with warning light	\$500
<b>DRIVER TRAINING</b>	
<input type="checkbox"/> 1 Day Training	\$0
<input type="checkbox"/> 2 Day Training - Operator and Maintenance at Customer Premises	\$0
<input type="checkbox"/> 3 Day Training	\$1,350
<input type="checkbox"/> 4 Day Training	\$1,700
<input type="checkbox"/> 5 Day Training	\$2,150
<b>TECHNICAL AND PARTS MANUAL</b>	
<input type="checkbox"/> Paper Copy x2	\$0
<input type="checkbox"/> Paper Copy - Additional	\$150
<input type="checkbox"/> USB x1	\$0
<input type="checkbox"/> USB - Additional	\$50
<b>SPECIFICS</b>	
<input type="checkbox"/> Custom Paint / Signwriting - P.O.A	\$0
<input type="checkbox"/> Auto Grease System	\$6,990
<input type="checkbox"/> Delivery - P.O.A.	\$0
<input type="checkbox"/> 12 months Road Registration and All Associated Costs - P.O.A.	\$0



DESCRIPTION	PRICE
<input type="checkbox"/> 12 months Road Registration and All Associated Costs - P.O.A.	\$0
<b>SUBTOTAL</b>	<b>\$394,447</b>
<b>TAX (10%)</b>	<b>+\$39,444.70</b>
<b>TOTAL</b>	<b>\$433,891.70</b>



# STG FINANCE

Discover the advantage of our low weekly repayment finance options, tailored to match your cashflow needs. We are proud to offer seamless inhouse finance that reflects the best deals in the market.

Meet our team of finance managers below, strategically positioned across Australia to ensure that you have a dedicated local finance consultant ready to provide personalised service and support



**Kristina Alexopoulos**  
0429 174 561  
kalexopoulos@finmanager.com.au  
VIC, SA, & Tasmania



**Jackson Atto**  
0406 380 755  
jatto@finmanager.com.au  
QLD



**Ian O'Meara**  
0402 107 714  
iomeara@finmanager.com.au  
NSW



**Jared Percival**  
0407 200 039  
jpercival@finmanager.com.au  
Western Australia





## STG PARTS

At STG, we prioritize efficiency and understand the importance of swift turnaround times. Experience the convenience of ordering the parts you need directly from the STG Parts Store. Our online platform ensures a seamless process, allowing you to access the required components without unnecessary delays.

Our knowledgeable and friendly experts are just a call away, ready to assist with any technical questions you may have. As the OEM, we take pride in stocking all parts for our builds at our World-Class National Distribution Centre in Pakenham, Victoria. This centralized hub ensures that our Parts Stores in New South Wales, Queensland, Western Australia, Northern Territory, and New Zealand remain consistently well-stocked, guaranteeing prompt fulfillment of your orders.

For our National Fleet customers, we also offer parts on a consignment arrangement, providing an additional layer of convenience and flexibility.

Choose STG for a streamlined parts experience that aligns with your business's pace and demands!

**Visit [www.stgparts.net](http://www.stgparts.net)**

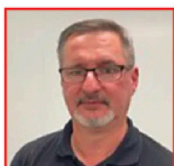

**Mark Geraghty**  
General Manager - Parts  
**STG Parts 1300 998 784 - Press Option 2**  
mark@stgglobal.net



-  **STG OFFICIAL SERVICE CENTRE**
-  **STG AUTHORISED SERVICE CENTRE**

-  **VICTORIA**  
29-31 Evolution Drive, Dandenong South, Victoria, Australia, 3175
-  **QUEENSLAND**  
49 Motorway Circuit, Ormeau, Queensland, Australia, 4208
-  **NEW SOUTH WALES**  
Unit A, 16 Cassola Place, Penrith, NSW, Australia, 2750
-  **WESTERN AUSTRALIA**  
25 Competition Way, Wangara, WA, Australia, 6065
-  **NEW ZEALAND**  
East Tamaki, Auckland



# CONDITIONS

## DELIVERY

A vehicle delivery date will be confirmed at time of order placement. Whilst STG Global endeavors to meet all programmed delivery schedules, STG Global cannot be held responsible for failure to deliver or delays due to circumstances beyond our control. STG Global can, on your instructions, register the Vehicle on your behalf. All paperwork is to be completed by the customer.

## WARRANTY

### STG GLOBAL WARRANTY:

- Five (5) year warranty on modules as detailed in STG Terms & Conditions - copy available on request. For full terms and conditions, and further warranty information on vehicles, please visit our [website](#).

### ISUZU STANDARD WARRANTY:

- New Vehicle: 6 years or 500,000 klms or 8000 engine hours whichever occurs first.

For more information on Isuzu's warranty, please visit their [website](#).

## ABOUT THIS OFFER

By signing this *non-binding indicative offer*, both parties acknowledge a confirmation on price, conditional of approval of finance and signing of official sale documents at the time of sale.

 SIGNATURE  
John Ware



Isuzu FVY 240-300 Dual Control 6A (GVM=24000) Air, STG  
Bandit 20m3, Alu-Wheels, 2 Crew, Full fuel

Mass Distribution Estimate  
Overview - Summary (Side)

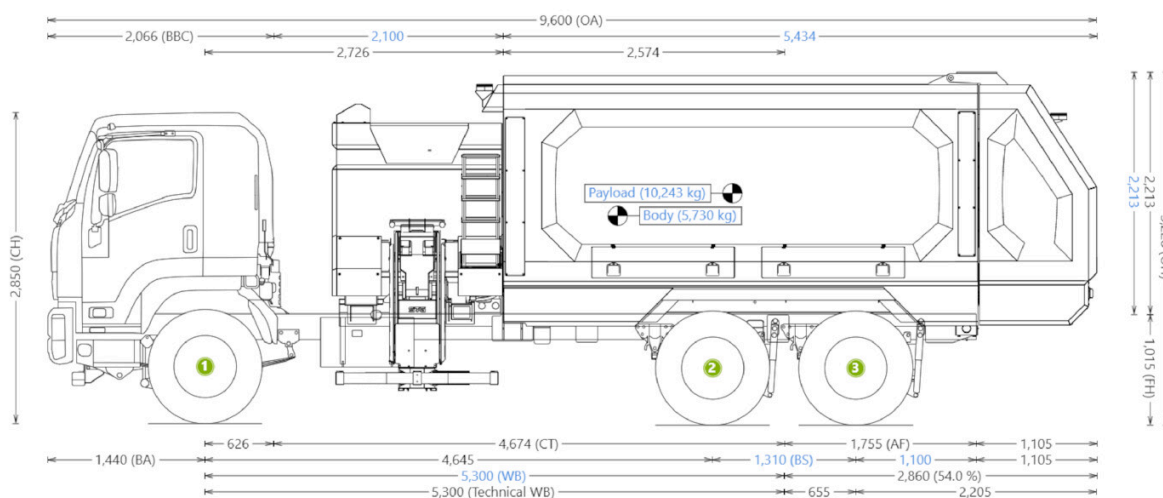

Dashboard		Masses Summary		
		Front (1)	Rear (2 - 3)	Total
Manufacturer Ratings	✓	3,530 kg	3,050 kg	6,580 kg
Regulatory Compliance	✓	289 kg	41 kg	330 kg
Organisation Standards	✓	1,648 kg	4,082 kg	5,730 kg
Gross Mass on Vehicle Front	6,383 kg	5,467 kg	7,173 kg	12,640 kg
Gross Mass on Vehicle Front (%)	27.9 %	916 kg	9,327 kg	10,243 kg
Gross Mass on Vehicle Rear	16,500 kg	6,383 kg	16,500 kg	22,883 kg
Gross Mass on Vehicle Rear (%)	72.1 %	6,500 kg	16,500 kg	23,000 kg
Static Rollover Angle of Vehicle	28.2°	117 kg	0 kg	117 kg
		98.2%	100.0%	99.5%

\* Refer to subsequent pages for notes and warnings

Prepared By: Connor Hunter	Phone:	Prepared For:	Phone:	Date Created: 17 Oct 2022
Signature:	Date:	Signature:	Date:	Page: 1 of 3

DISCLAIMER: Information in this report is based on reasonably available data and assumptions, and only constitutes estimates. The originator and supplier of the report therefore do not guarantee the correctness of the information. They shall not be liable for consequential or other loss or damage caused by reliance thereon, and the recipient of the information indemnifies them against such liability.





Isuzu FVY 240-300 Dual Control 6A (GVM=24000) Air, STG  
Bandit 20m3, Alu-Wheels, 2 Crew, Full fuel

Mass Distribution Estimate  
Weight & Centre of Gravity

Significant Dimensions

Theoretical Wheelbase	5,300 mm
Track Width - Front	2,010 mm
Track Width - Rear	1,840 mm

Centre of Gravity & Weight Distribution - Vehicle

Description	Horizontal COG *	Vertical COG *	Lateral COG *	Front	Rear	Total
Isuzu FVY 240-300 Dual Control 6A (GVM=24000) Air	2,457 mm	900 mm	0 mm	3,530.0 kg	3,050.0 kg	6,580.0 kg
Fuel Tank 1	1,484 mm	780 mm	-773 mm	114.9 kg	44.7 kg	159.6 kg
Crew 1st Row	-130 mm	1,650 mm	0 mm	174.2 kg	-4.2 kg	170.0 kg
Bandit 20m3	3,776 mm	1,915 mm	0 mm	1,647.6 kg	4,082.4 kg	5,730.0 kg
Payload	4,826 mm	2,122 mm	0 mm	916.1 kg	9,327.1 kg	10,243.2 kg
<b>Total</b>	<b>3,822 mm</b>	<b>1,706 mm</b>	<b>-5 mm</b>	<b>6,382.8 kg</b>	<b>16,500.0 kg</b>	<b>22,882.8 kg</b>

\* Horizontal COG is measured from Theoretical Wheelbase start; Vertical COG is measured from the ground; Lateral COG from the centre

Prepared By: Connor Hunter

Phone:

Date Created: 17 Oct 2022

Prepared For:

Phone:

Page: 2 of 3

DISCLAIMER: Information in this report is based on reasonably available data and assumptions, and only constitutes estimates. The originator and supplier of the report therefore do not guarantee the correctness of the information. They shall not be liable for consequential or other loss or damage caused by reliance thereon, and the recipient of the information indemnifies them against such liability.





Isuzu FVY 240-300 Dual Control 6A (GVM=24000) Air, STG  
Bandit 20m3, Alu-Wheels, 2 Crew, Full fuel

Mass Distribution Estimate  
Weight & Centre of Gravity

Notes & Warnings

Notes

Manufacturer Ratings

- The compliance indicators for Manufacturer Ratings refer to Gross Axle and Gross Vehicle Mass ratings only.

Regulations Applied

- AU: National
- Mass Limits = On Road

General

- Included = 200.0 l Fuel, 2 Crew at 85.0 kg per person
- Excluded = Tools, Spare Wheel, 5th Wheel
- Overall centre of gravity includes chassis cab, crew, fuel, equipment & payload
- Model Code = FH-FVYTZ-L20
- Vehicle Spec Date: 2020/06
- Measurement System = Metric
- Body & Equipment Added = Bandit 20m3
- External Body Width = 2,450 mm
- Vehicle wheelbase has been extended by 890 mm
- Engineering approval is required for this wheelbase
- The default value for Theoretical Wheelbase has been changed
- The default value for Chassis Mass has been changed
- The default Vertical Centre of Gravity for vehicle has been estimated
- The Smallest Turning Circle is used to determine the smallest U-turn that the vehicle is capable of making
- The vehicle's static rollover angle is 28.2°

Warnings

Additional Notes

Customer Acknowledgement:

I acknowledge that the TruckScience weight and balance drawing provided to me by an STG Global is for information purposes only. It is based on information that myself and other suppliers have provided and is only an estimate of the actual load that the Truck can carry under normal operating conditions. As it is only a guide, it is my responsibility to carefully evaluate the accuracy and completeness of all information that may affect the actual load that the Truck can carry in the conditions I expect it to operate in. It is possible that the estimated load capacity in the drawing may be different to the Truck's actual load capacity. I do not hold STG Global, the body builder, or any employee or agent responsible for any wrong or incorrect information in this TruckScience weight and balance drawing.

Prepared By: Connor Hunter

Phone:

Date Created: 17 Oct 2022

Prepared For:

Phone:

Page: 3 of 3

DISCLAIMER: Information in this report is based on reasonably available data and assumptions, and only constitutes estimates. The originator and supplier of the report therefore do not guarantee the correctness of the information. They shall not be liable for consequential or other loss or damage caused by reliance thereon, and the recipient of the information indemnifies them against such liability.



**3 NEXT MEETING**

**4 CLOSURE**